

INSTALLATION INSTRUCTIONS

SAILDRIVE

- see that the spacer supplied with your saildrive is mounted.
- make sure your anode has good contact with the saildrive.
- mount the hub (1) on the splined shaft (2) and apply a small drop of loctite "low" to the thread of the nut (3). Tighten the nut (3) while countering the hub with the hook wrench (7).

(See the torque specification for nut (3) in the installation instruction of your saildrive)

After installation, check that the hub does not move axial on the saildrive shaft. If so, fit one or more of the different spacer disc (8) between the forward end of the prop and the saildrive disc to reduce it. The spacer discs are delivered with the prop.

- apply a small drop of loctite "low" to the thread of the set-screw (4) and tighten (20 Nm / 15 Ft.lb) to secure the prop nut (3).
- now screw the blade assembly (5) clockwise onto the large thread of hub (1) until you fit the prop strongly onto the hub (1).

Do not use Loctite on the thread of the blade assembly (5)!

- Make sure that the set screw holes for set screw (6) are aligned with the borings of the hub.
- Take care that the set screws (6) are plane with housing while set screw tighten. (see Detail A & B)
- apply a small drop of loctite "medium" to the thread of the set screws (6) and tighten (20 Nm / 15 Ft.lb).
- check the function and see that the blade movement is free.

Detail A – "OK"

Detail B – wrong!

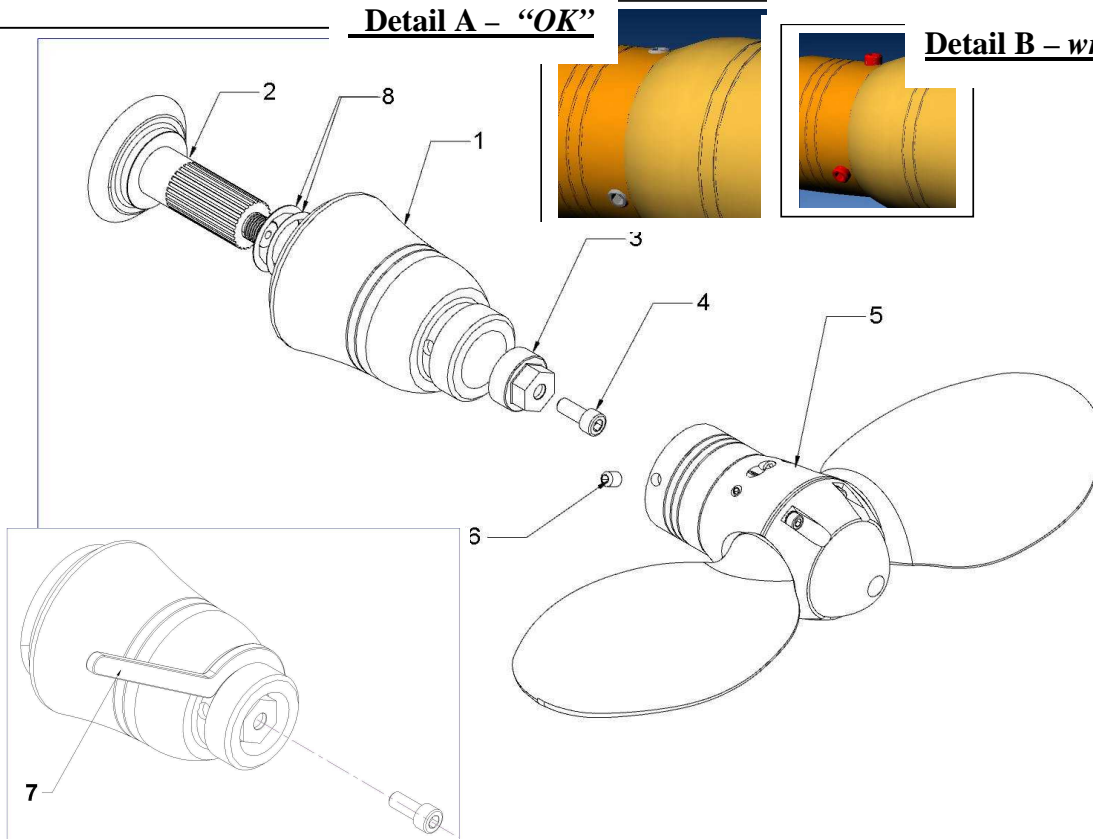

1. Hub
2. Shaft
3. Nut (SW24)
4. Set-Screw M8x20
5. Blade assembly
6. Set-Screw M8x12
7. Hook Wrench 45-50
8. Spacer-Disc
1off -0,5 & 2off - 0,25mm
(Only use if needed)

WARNING:

Engage forward/reverse at idling RPM's only. Stop the engine immediately if any strange sounds or vibrations are noticed coming from the propeller. Check that the propeller works in both forward and reverse before starting each voyage. Do not start the the engine until the boat is in the water. Keep away from moving parts while handling the propeller, the blades are like knives, and can cause considerable damage. Do not attempt to come close to the propeller unless the engine is stopped.

PITCH ADJUSTMENT

In general the pitch settings are done in the factory and are ready set for your boat and engine. Should it be necessary to adjust the pitch it is very simple on the VARIPROFILE, and can be done in or out of the water in a matter of few minutes.

Possible reasons for pitch adjusting might be:

- If the engine does not reach the desired RPM reduce the forward pitch.
- If the engine exceeds the desired RPM increase the forward pitch.
- If the prop walk in astern is too strong reduce reverse pitch.



Marked lettering of a LH Propeller

Example below is showing a RH display

LH lettering is marked to Detail "D" & "E"

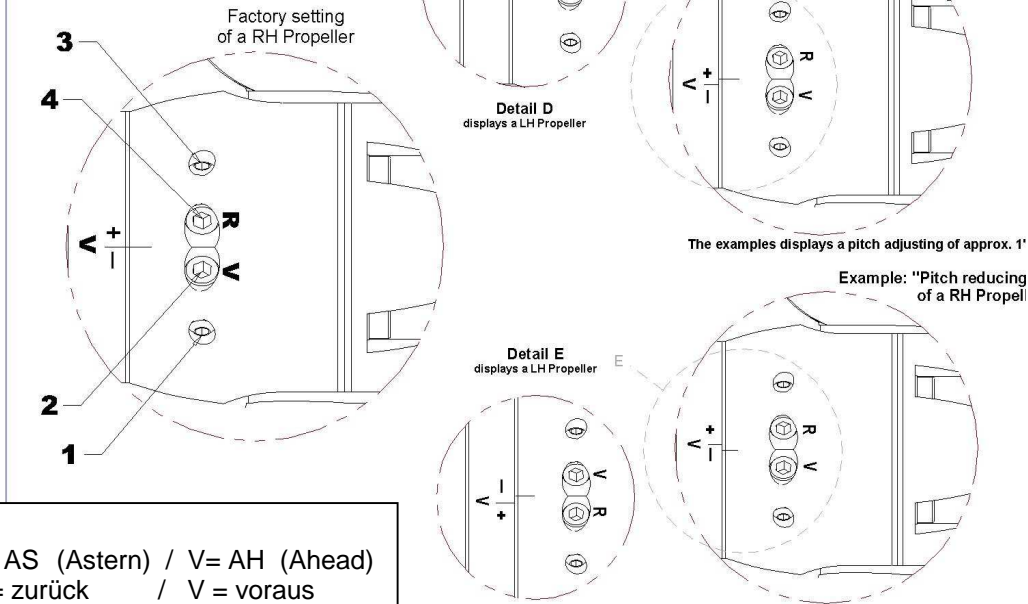

R= AS (Astern) / V= AH (Ahead)
R = zurück / V = voraus

It is quite possible to set the pitch continuously variable and independently for forward and reverse. The turning of the adjusting screws (2) & (4) in Figure "Example" by half a revolution changes the pitch approx. 1". That means a quarter turn (90°) changes the pitch by 1/2" and a one full turn by 2" etc. For a check of pitch adjustments there are markings on the hub rotating flange. To return to original factory pitch settings, line up "V" resp. "R" markings on the hub face. (see example beside)

Possible adjustment range see pitch sheet at next page*!

B. Adjusting the forward pitch: "V"

1. Loose the set screw (1) - 3mm Allen key.
Under water: only 2 turns.
2. Turn the adjusting screw (2) which is marked as "V" with the 4mm Allen key as follows

2a. Increasing of pitch:

- Turn the adjusting screw (2) clockwise.
- Secure set screw (1) with LOCTITE low (pink)
Lock set screw (1) 3 Nm / 2 Ft.lb.

2b. Reducing of pitch:

- Turn the adjusting screw (2) anti-clockwise.
- Secure set screw (1) with LOCTITE low (pink)
Lock set screw 3 Nm / 2 Ft.lb.

A. Adjusting the reverse pitch: "R"

3. Loose the set screw (3) - 3mm Allen key.
Under water: only 2 turns.
4. Turn the adjusting screw (4) which is marked as "R" with the 4mm Allen key as follows

2a. Increasing of pitch:

- Turn the adjusting screw (4) anti-clockwise.
- Secure set screw (3) with LOCTITE low (pink)
Lock set screw (3) 3 Nm / 2 Ft.lb.

2b. Reducing of pitch:

- Turn the adjusting screw (4) clockwise.
- Secure set screw (3) with LOCTITE low (pink)
Lock set screw 3 Nm / 2 Ft.lb.

NOTE: It is quite possible to set the pitch continuously variable and independently for forward and reverse. Turning of the adjusting screws (2) & (4) by half a revolution (180°) changes the pitch approx. 1". This will change the engine revolution by approx. 200.

Appendix: 1A

Pitch adjustment table

Rev.: 02 / 09-08

VARIPROFILE[®]
Feathering Propeller

A product of

SPW GmbH
GERMANY

Pitch adjustment table VARIPROFILE VP-64 / RH&LH

2 blade ahead (V)

3 blade ahead (V)

Prop.-ø	ahead min.	ahead max.	Prop.-ø	ahead min.	ahead max.
	tolerance: ±0.3"	tolerance: ±0.3"		tolerance: ±0.3"	tolerance: ±0.3"
13"	7.5"	12"	13"	7"	12"
14"	8"	13"	14"	7.5"	12.5"
15"	9"	14"	15"	8"	13"
16"	9.5"	15"	16"	9"	14"
17"	10"	15.5"	17"	9.5"	14.5"
18"	10.5"	16"	18"	10"	15"

2 blade astern (R)

3 blade astern (R)

Prop.-ø	astern min.	astern max.	Prop.-ø	astern min.	astern max.
	tolerance: ±0.3"	tolerance: ±0.3"		tolerance: ±0.3"	tolerance: ±0.3"
13"	7"	12"	13"	6.5"	11.5"
14"	8"	13"	14"	7"	12"
15"	9"	14"	15"	8"	13"
16"	10"	15"	16"	9"	14"
17"	10.5"	16.5"	17"	9.5"	14.5"
18"	11"	17"	18"	10"	15"

The VARIPROFILE feathers automatically when the shaft rotation is stopped. After engine start-up and shifting into gear the blades will engage in either forward or reverse.

THE BEST WAY TO FEATHER THE PROPELLER IN THE SAILPOSITION IS:

VARIPROFILE sailposition with mechanical gear-box:

- + Power at 2 to 3 knots in forward.
- + **Stop the engine** and engage the transmission in reverse to stop the freewheeling of the shaft.

VARIPROFILE sailposition with hydraulic transmission:

- + Power at 3 to 4 knots in forward.
- + Stop the engine while still engaged in forward. The remaining oil pressure of the transmission will stop spinning the shaft to feather the blades in the sailposition.

If the propeller is not feathered in the sailposition the shaft will freewheel like with a fixed propeller. In that case start the engine again and repeat the steps above. Once the prop is feathered, you may remain in gear or shift into neutral.

DO NOT stop the engine while it turns in reverse. In this case the blades will stay in the reverse position and will not feather. *You can actually use this feature to drive a shaft generator.*

TROUBLE SHOOTING: If the propeller does not work in forward or reverse go systematically through the points below:

- + Check low idle of the engine. It should be 900 to 1000 rpm in idle.
- + Check shifting movement of the transmission lever. Make sure that the shifting travel is not too short. The amount of lever travel, as measured at the pivot point of the actuating lever, between the neutral position and end positions for forward and reverse can be found in the owners manual of your transmission. A larger amount of lever travel is in no way detrimental.
- + Check the clutch discs of the transmission. They could be worn out.

WARNING: It is important to follow the instructions below carefully so as to avoid excessive load and shock to the gears, shortening their life.

- + When going from ahead to astern or the opposite, it is necessary to idle down and shift at low rpm's (max.1200rpm) between gears to allow smooth reversing of rotation without binding. This will substantially lengthen the service life of your propeller gears.
- + When going from ahead to astern or the opposite, you can hear the turning-noise of the feathering blades. This is normal and not a problem or a defect of your VARIPROFILE.
- + The propeller body must always be completely filled with a high viscosity grease. We recommend synthetic grease typ TW.2 GEL or mineral multi-purpose grease EP/SAL
- + The propeller must be protected from electrolytic corrosion by fitting the usual zinc anodes on the shaft plus the prop anode. We recommend the replacement of the anode once a year.
- + If you want to protect your VARIPROFILE with Antifouling, use only Antifouling which needs a primer first. Otherwise chemical interaction and decomposition could occur. Our recommendation is *Velox TF plus* including a primer (offers also protection against electrolyses), available from your VARIPROFILE distributor.

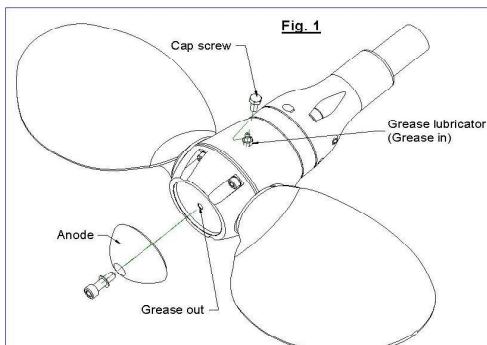

SERVICING

The VARIPROFILE needs to be greased a minimum of once a year with the special EP/SAL lubricant available from your VARIPROFILE dealer.

The VARIPROFILE body should always be completely filled with a high viscosity grease of a hydrophobic nature. Remove the cap screw and screw in the lubricating nipple which is supplied with the tools. Further remove the zinc anode! With each pump of the grease gun rotate the propeller from forward stop to reverse stop to allow the grease to work through the propeller. Stop to pump when enough grease comes out of the anode drill hole on top of the prop (Fig.1).

- + Factory supplied special grease EP/SAL is recommended and available from your VARIPROFILE distributor. **Avoid regular white grease (sterntube-grease) !**

+ Never dismantle the VARIPROFILE yourself

Disassembly and reassembly require special tools and technical know-how only available at the factory or their approved service centres.