

STANDARD SHAFT

- mount the hub (1) on the shaft (2). Make sure the prop taper and keyway mate properly with shaft and key and the top of the key does not touch the hub! File key if necessary.
- Fit the counter screw (9) into the thread for the setscrew.
- **Pay attention not to set the prop nut with the counter screw!**
- apply a small drop of loctite "medium" to the threads of the nut (3) and tighten strongly 80 Nm / 60 Ft.lb), while blocking the hub with one hand against the counter screw.
- after tightening the prop nut (3) remove the counter screw (9)
- apply a small drop of loctite to the thread of the setscrew (4) and tighten (20 Nm / 15 Ft.lb.).

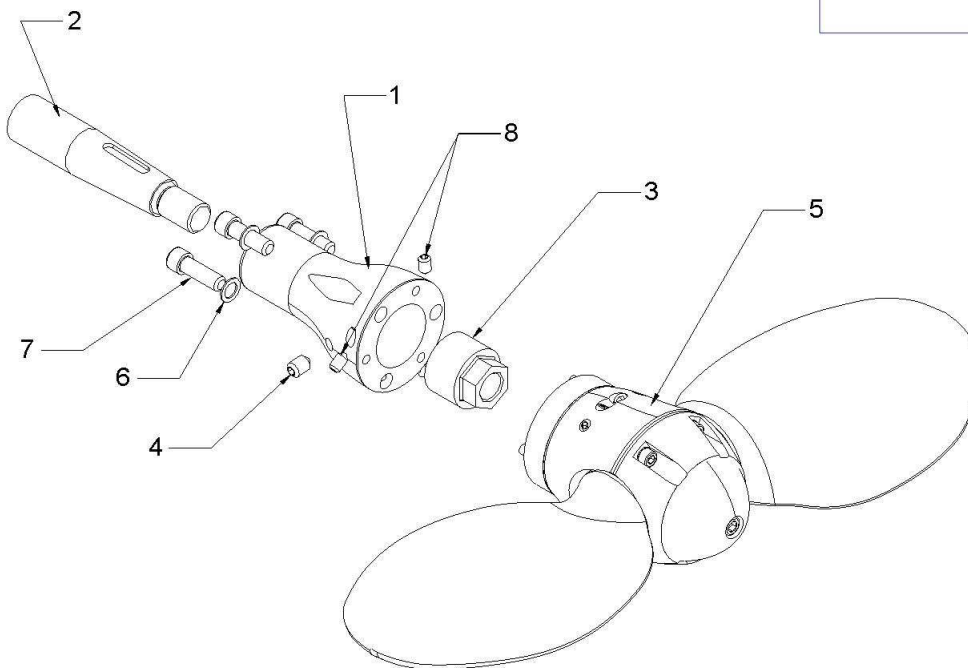
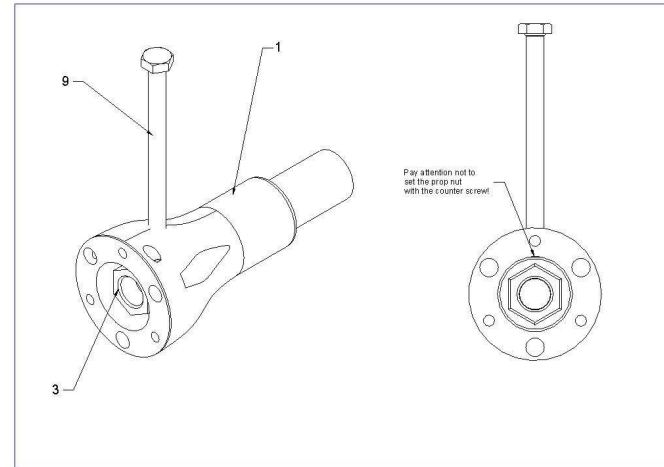

1. Hub
2. Shaft
3. Nut (SW30)
4. Set-Screw M8x16
5. Blade assembly
6. Washer $\varnothing 10$
7. Socket Screws M10x30
8. Set-Screw M8x12
9. Counter Screw M8x120

A product of

SPW GmbH
GERMANY

- align the blade assembly (5) with the boring and pivot pins and push onto the hub (1).
- mount the socket screws (7) with washers (6) and tighten (50 Nm / 37 Ft.lb). use loctite "medium" to secure the socket-screws (7).
- apply a small drop of loctite "low" to the threads of the set screws (8) and tighten (10 Nm / 7 Ft.lb)
- check the function and see that the blade movement is free.
- make sure you have a shaft anode with good contact to the shaft.

WARNING:

Engage forward/reverse at idling RPM's only. Stop the engine immediately if any strange sounds or vibrations are noticed coming from the propeller. Check that the propeller works in both forward and reverse before starting each voyage. Do not start the the engine until the boat is in the water. Keep away from moving parts while handling the propeller, the blades are like knives, and can cause considerable damage. Do not attempt to come close to the propeller unless the engine is stopped.

PITCH ADJUSTMENT

In general the pitch settings are done in the factory and are ready set for your boat and engine. Should it be necessary to adjust the pitch it is very simple on the VARIPROFILE, and can be done in or out of the water in a matter of few minutes.

Possible reasons for pitch adjusting might be:

- If the engine does not reach the desired RPM reduce the forward pitch.
- If the engine exceeds the desired RPM increase the forward pitch.
- If the prop walk in astern is too strong reduce reverse pitch.

Example below is showing a RH display

LH lettering is marked to Detail "D" & "E"

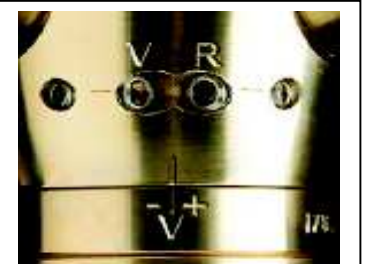

Marked lettering of a LH Propeller

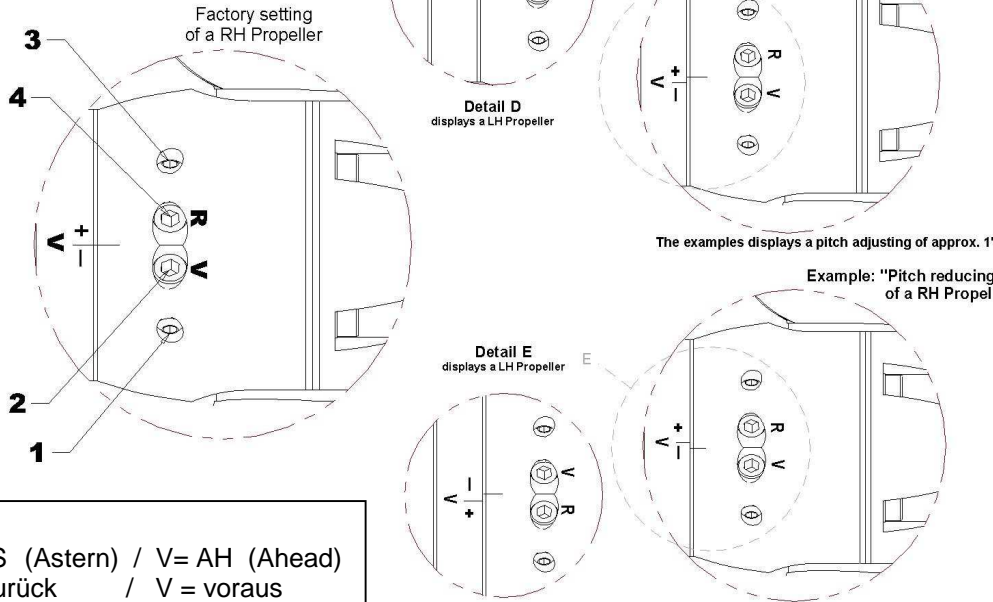

It is quite possible to set the pitch continuously variable and independently for forward and reverse. The turning of the adjusting screws (2) & (4) in Figure "Example" by half a revolution changes the pitch approx. 1.5". That means a quarter turn (90°) changes the pitch by 3/4" and a one full turn by 3" etc. For a check of pitch adjustments there are markings on the hub rotating flange. To return to original factory pitch settings, line up "V" resp. "R" markings on the hub face. (see example beside)

R= AS (Astern) / V= AH (Ahead)
R = zurück / V = voraus

Possible adjustment range see pitch sheet at next page*!

B. Adjusting the forward pitch: "V"

1. Loose the set screw (1) - 4mm Allen key.
Under water: only 2 turns.
2. Turn the adjusting screw (2) which is marked as "V" with the 5mm Allen key as follows

2a. Increasing of pitch:

- Turn the adjusting screw (2) clockwise.
- (see "NOTE")
- Secure set screw (1) with LOCTITE low (pink)
Lock set screw (1) 5 Nm / 3.5 Ft.lb.

2b. Reducing of pitch:

- Turn the adjusting screw (2) anti-clockwise.
- (see "NOTE").
- Secure set screw (1) with LOCTITE low (pink)
- Lock set screw 5 Nm / 3.5 Ft.lb.

A. Adjusting the reverse pitch: "R"

1. Loose the set screw (3) - 4mm Allen key.
Under water: only 2 turns.
2. Turn the adjusting screw (4) which is marked as "R" with the 5mm Allen key as follows

2a. Increasing of:

- Turn the adjusting screw (4) anti-clockwise.
- (see "NOTE")
- Secure set screw (3) with LOCTITE low (pink)
Lock set screw (3) 5 Nm / 3.5 Ft.lb.

2b. Reducing of pitch:

- Turn the adjusting screw (4) clockwise.
- (see "NOTE").
- Secure set screw (3) with LOCTITE low (pink)
- Lock set screw 5 Nm / 3.5 Ft.lb.

NOTE: It is quite possible to set the pitch continuously variable and independently for forward and reverse. Turning of the adjusting screws (2) & (4) by third a revolution (120°) changes the pitch approx. 1". This will change the engine revolution by approx. 200.

Appendix: 1A

Pitch adjustment table



A product of



Rev.: 01 / 09-08

Pitch adjustment table VARIPROFILE VP-76/RH

2 blade ahead (V)

3 blade ahead (V)

Prop.-ø	ahead min.	ahead max.	Prop.-ø	ahead min.	ahead max.
	tolerance: ±0.3"	tolerance: ±0.3"		tolerance: ±0.3"	tolerance: ±0.3"
17"	11"	17"	17"	11.5"	17"
18"	11.5"	18"	18"	12"	18"
19"	12.5"	18"	19"	13"	19"
20"	12.5"	19"	20"	13"	19"
21"	13"	19"	21"	13.5"	20"
22"	14"	20"	22"	14.5"	21"

2 blade astern (R)

3 blade astern (R)

Prop.-ø	astern min.	astern max.	Prop.-ø	astern min.	astern max.
	tolerance: ±0.3"	tolerance: ±0.3"		tolerance: ±0.3"	tolerance: ±0.3"
17"	9"	15"	17"	10"	16"
18"	10"	16"	18"	10"	16.5"
19"	11"	17.5"	19"	11"	17"
20"	11"	17.5"	20"	12"	18"
21"	12"	18.5"	21"	13"	19"
22"	13"	19.5"	22"	14"	20"

Pitch adjustment table VARIPROFILE VP-76/LH

2 blade ahead (V)

3 blade ahead (V)

Prop.-ø	ahead min.	ahead max.	Prop.-ø	ahead min.	ahead max.
	tolerance: ±0.3"	tolerance: ±0.3"		tolerance: ±0.3"	tolerance: ±0.3"
17"	10.5"	17"	17"	11.5"	17"
18"	11.5"	18"	18"	12"	18"
19"	11.5"	18"	19"	13"	19"
20"	12"	19"	20"	13"	19"
21"	12.5"	19"	21"	13.5"	20"
22"	13"	19"	22"	14.5"	20"

2 blade astern (R)

3 blade astern (R)

Prop.-ø	astern min.	astern max.	Prop.-ø	astern min.	astern max.
	tolerance: ±0.3"	tolerance: ±0.3"		tolerance: ±0.3"	tolerance: ±0.3"
17"	8"	14.5"	17"	8"	14"
18"	9"	15"	18"	9"	15"
19"	10"	16"	19"	10"	16.5"
20"	10"	16.5"	20"	11"	17"
21"	11"	17"	21"	12"	18"
22"	12"	18"	22"	12"	18"

The VARIPROFILE feathers automatically when the shaft rotation is stopped. After engine start-up and shifting into gear the blades will engage in either forward or reverse.

THE BEST WAY TO FEATHER THE PROPELLER IN THE SAILPOSITION IS:

VARIPROFILE sailposition with mechanical gear-box:

- + Power at 2 to 3 knots in forward.
- + **Stop the engine** and engage the transmission in reverse to stop the freewheeling of the shaft.

VARIPROFILE sailposition with hydraulic transmission:

- + Power at 3 to 4 knots in forward.
- + Stop the engine while still engaged in forward. The remaining oil pressure of the transmission will stop spinning the shaft to feather the blades in the sailposition.

If the propeller is not feathered in the sailposition the shaft will freewheel like with a fixed propeller. In that case start the engine again and repeat the steps above. Once the prop is feathered, you may remain in gear or shift into neutral.

DO NOT stop the engine while it turns in reverse. In this case the blades will stay in the reverse position and will not feather. *You can actually use this feature to drive a shaft generator.*

TROUBLE SHOOTING: If the propeller does not work in forward or reverse go systematically through the points below:

- + Check low idle of the engine. It should be 900 to 1000 rpm in idle.
- + Check shifting movement of the transmission lever. Make sure that the shifting travel is not too short. The amount of lever travel, as measured at the pivot point of the actuating lever, between the neutral position and end positions for forward and reverse can be found in the owners manual of your transmission. A larger amount of lever travel is in no way detrimental.
- + Check the clutch discs of the transmission. They could be worn out.

WARNING: It is important to follow the instructions below carefully so as to avoid excessive load and shock to the gears, shortening their life.

- + When going from ahead to astern or the opposite, it is necessary to idle down and shift at low rpm's (max.1200rpm) between gears to allow smooth reversing of rotation without binding. This will substantially lengthen the service life of your propeller gears.
- + When going from ahead to astern or the opposite, you can hear the turning-noise of the feathering blades. This is normal and not a problem or a defect of your VARIPROFILE.
- + The propeller body must always be completely filled with a high viscosity grease. We recommend synthetic grease typ TW.2 GEL or mineral multi-purpose grease EP/SAL
- + The propeller must be protected from electrolytic corrosion by fitting the usual zinc anodes on the shaft plus the prop anode. We recommend the replacement of the anode once a year.
- + If you want to protect your VARIPROFILE with Antifouling, use only Antifouling which needs a primer first. Otherwise chemical interaction and decomposition could occur. Our recommendation is *Velox TF plus* including a primer (offers also protection against electrolyses), available from your VARIPROFILE distributor.

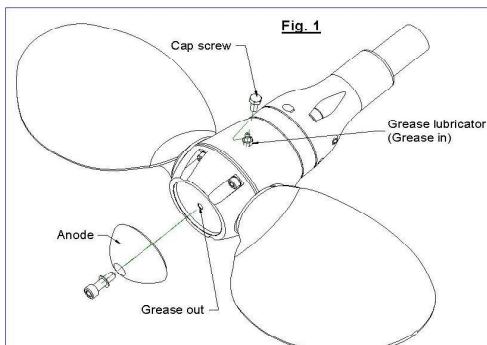

SERVICING

The VARIPROFILE needs to be greased a minimum of once a year with the special EP/SAL lubricant available from your VARIPROFILE dealer.

The VARIPROFILE body should always be completely filled with a high viscosity grease of a hydrophobic nature. Remove the cap screw and screw in the lubricating nipple which is supplied with the tools. Further remove the zinc anode! With each pump of the grease gun rotate the propeller from forward stop to reverse stop to allow the grease to work through the propeller. Stop to pump when enough grease comes out of the anode drill hole on top of the prop (Fig.1).

- + Factory supplied special grease EP/SAL is recommended and available from your VARIPROFILE distributor. **Avoid regular white grease (sterntube-grease) !**

+ Never dismantle the VARIPROFILE yourself

Disassembly and reassembly require special tools and technical know-how only available at the factory or their approved service centres.

STANDARD SHAFT

DO NOT DISMANTLE THE PROPELLER UNIT (5)!!

- Remove the blade assembly (5) from the hub (1).
- Therefore remove first the 3 off Set-Screws (8).
- Now you can remove the Socket Screws (7).

Take care that the prop will not fall off after removing all Socket Screws!

- Dismount the blade assembly (5) from the hub (1).
- Remove the Set-Screw (4) completely and screw into the same hole (M8) the Counter Screw (9).

Pay attention not to set the prop nut with the counter screw!

- now remove the prop nut (3) while blocking the hub with one hand against the counter screw.

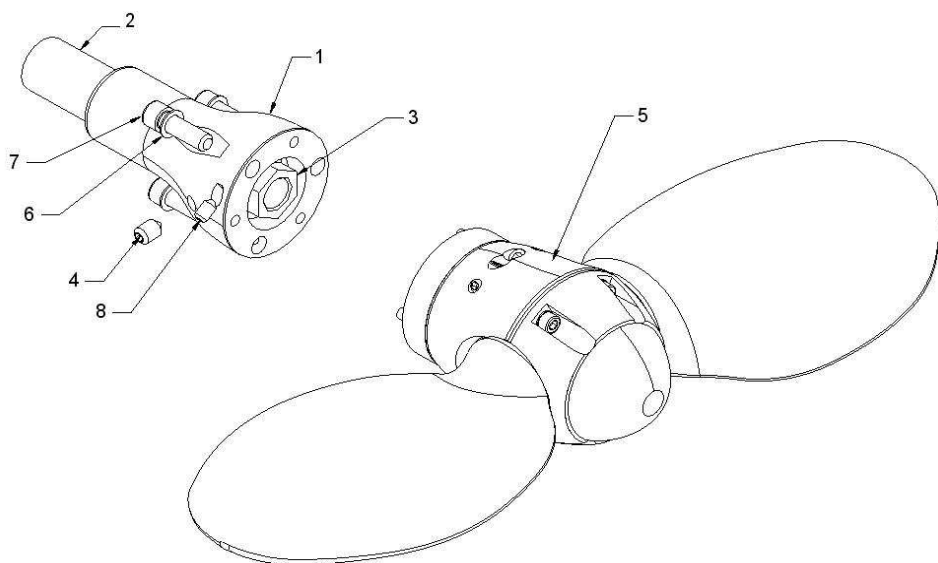
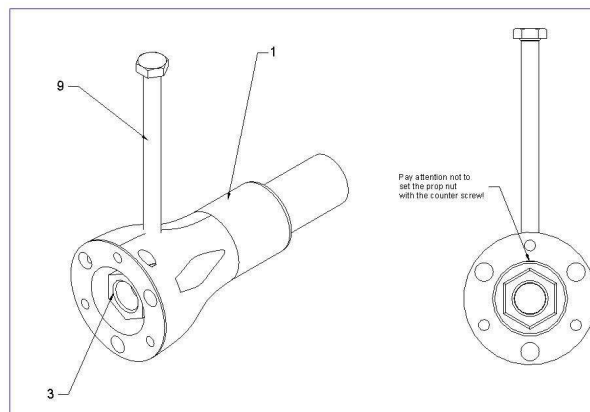

1. Hub
2. Shaft
3. Nut (SW30)
4. Set-Screw M8x16
5. Blade assembly
6. Washer $\varnothing 10$
7. Socket Screws M10x30
8. Set-Screw M8x12
9. Counter Screw M8x120

A product of

It is recommended to only use the special puller available from your VARIPROFILE dealer.

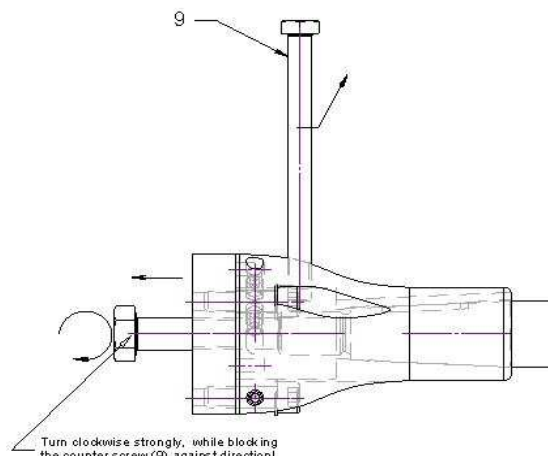
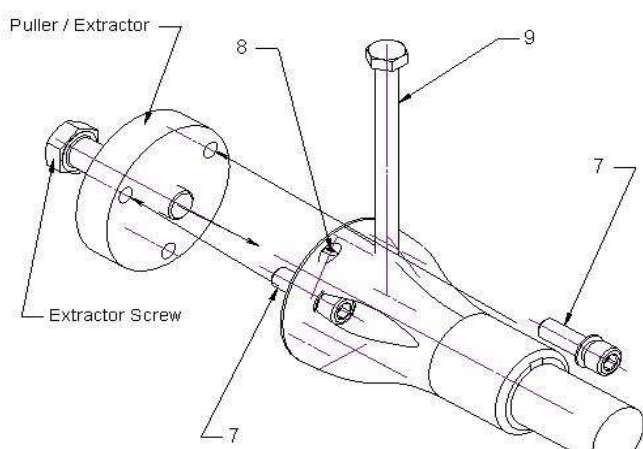

- align the puller with the socket screws (7) of the hub (1) and tighten (25 Nm / 18.5 Ft.lb).
- do **not** tighten the set screws (8)!
- tighten the extractor screw clockwise strongly, while holding by hand the counter screw (9).
- you can now remove the hub from the shaft.

Torque settings for the prop-nut

Standard – thread

M 14 x 2
UNC 1/2 " -13 40 Nm / 30 ft/lb

M 16 x 2
BSW 5/8 " – 11 60 Nm / 45 ft/lb
UNC 5/8 " - 11

M 16 x 2
Yanmar Saildrive 60 Nm / 45 ft/lb
SD 20 & SD 31

M 20 x 2,5
BSW 3/4 " – 10 125 Nm / 95 ft/lb
UNC 3/4 " - 10

UNC 7/8 " -9 160 Nm / 115 ft/lb

M 22 x1,5
M 24 x 3
BSW 1 " - 8 210 Nm / 155 ft/lb
UNC 1 " - 8

M 27 x 3 315Nm / 230 ft/lb

M 30 x 3,5
UNC 1 1/8" - 7 350 Nm / 255 ft/lb

Fine – thread

M 14 x 1,5
BSF 1/2 " - 16 40 Nm / 30 ft/lb

M 16 x 1,5
BSF 5/8 " – 14 70 Nm / 50 ft/lb
UNC 5/8 " - 18

M 18 x 1,5
M 20 x 2
Yanmar Saildrive 100 Nm / 75 ft/lb
SD 40 & SD 50

M 20 x 1,5
BSF 3/4 " – 12 135 Nm / 100 ft/lb
UNC 3/4 " - 16

M 24 x 2
BSF 1 " - 10 225 Nm / 165 ft/lb
UNF 1 " - 12

M 30 x 2 430 Nm / 315 ft/lb